

ASSEMBLY INSTRUCTIONS & PARTS MANUAL



Industrial Workbench with Steel Top

RETAIN INSTRUCTIONS FOR FUTURE REFERENCE



LOAD CAPACITIES FOR STEEL TOP	
UNIT SIZE	WT. CAPACITY
48w x 30d	4000 lbs.
60w x 30d	2500 lbs.
72w x 30d	1800 lbs.
96w x 30d	4000 lbs.
60w x 36d	2500 lbs.
72w x 36d	1800 lbs.
96w x 36d	4000 lbs.

*96" w workbenches have 3 sets of legs.

PLEASE NOTE: These instructions are for a workbench with flared or adjustable legs. If you have ordered a modular workbench (with modular door or drawer units instead of legs) please disregard these instructions and assemble using the instructions that came with your modular units.



NOTE: Additional accessories shown above are sold separately.

GENERAL SAFETY INFORMATION

Some parts may have sharp edges. CARE must be taken when handling various pieces to avoid injury. For safety, wear a pair of work gloves when assembling or performing any maintenance on units.

LIMITED WARRANTY

Tennsco warrants goods purchased hereunder to be free of defects in materials and workmanship for a period of one (1) year from the date of shipment, hereunder. This warranty shall not apply in the event goods are damaged as a result of misuse, abuse, neglect, accident, improper application, modification or repair by persons not authorized by Seller, where goods are damaged during shipment, or where the date stamps on the goods have been defaced, modified or removed. UNLESS CONSIDERED UNENFORCEABLE OR UNLAWFUL UNDER APPLICABLE LAW:

- a. ALL IMPLIED WARRANTIES, INCLUDING BUT NOT LIMITED TO WARRANTIES OR MERCHANTABILITY AND FITNESS FOR A PARTICULAR PURPOSE ARE HEREBY EXCLUDED;
- b. BUYERS REMEDY, IF ANY, FOR ANY DEFECTIVE GOODS SHALL BE LIMITED TO A REFUND BY SELLER OR REPLACEMENT OF THE GOODS AT SELLER'S OPTION, AND SHALL IN NO EVENT INCLUDE DAMAGES OF ANY KIND, WHETHER INCIDENTAL, CONSEQUENTIAL OR OTHERWISE.

NO GOODS ACCEPTED FOR RETURN WITHOUT PRIOR APPROVAL. Seller shall have the right to inspect any goods claimed to be defective at Buyers place of business or require Buyer to return the goods to Seller for inspection on Seller's premises. Transportation charges covering returned goods will be borne by Seller only if such goods are proven to be defective, are covered by this warranty and are returned within the warranty period stated above.



PROUDLY MADE IN THE U.S.A.

Tennsco LLC., Dickson, TN 37056-1888 • (866) 446-8686

ASSEMBLY OF STEEL TOP INDUSTRIAL WORKBENCH

Two people are recommended for assembly. Approximate assembly time: 40-45 minutes.

The reference numbers used throughout this sheet refer to the illustration on the back cover. This is to help you to identify the various parts as they are mentioned.

1. Lay the top (Ref. No. 1) face down on two sawhorses or a protected flat surface. Place a workbench leg (Ref. No. 4) on the top, aligning the four end holes as shown below. Attach it by first threading two $\frac{1}{4}$ "-20 x $\frac{5}{8}$ " bolts (Ref. No. 18) through the leg and the top. Then insert two more bolts through the leg and top and secure.. Attach the second leg the in the same manner.

NOTE: The drawings throughout this instruction sheet show the flared leg. If your bench came with adjustable legs, the legs will look different than the drawings shown throughout these instructions. The drawing here illustrates an example of both leg styles: the flared leg (shown at right) and the adjustable leg (shown at left). Both legs will attach the same way to the top.

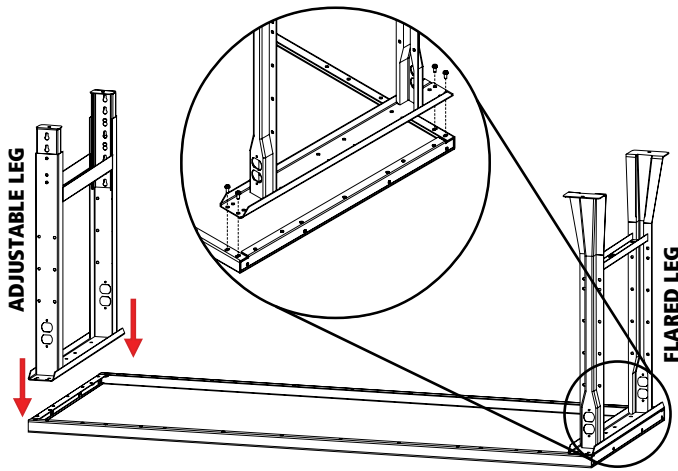

NOTE: When assembling a 96" workbench, the third leg should be mounted in the center of the top to reinforce the tops stability and allow for the load capacity.

2. The two mounting brackets (Ref. No. 3) are used either for additional desktop support or to mount a workbench drawer. If you are adding the drawer to your bench, skip to step 3. Otherwise, center and attach the two brackets under the lip of the bench top for extra support, using one bolt on each end of each bracket. The brackets should be evenly spaced for maximum support.

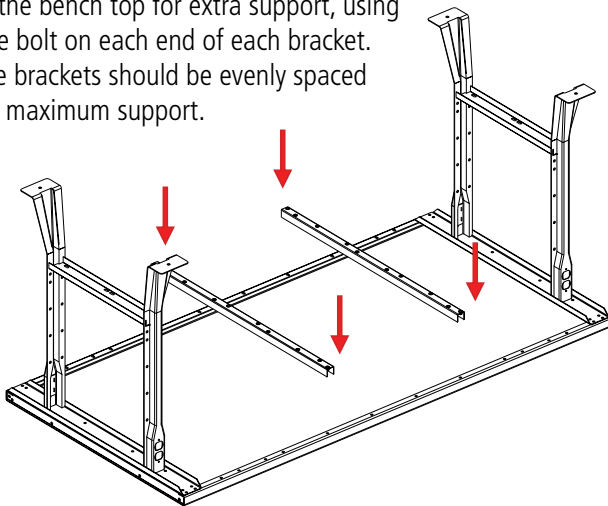

3. Attach the stringer (Ref. No. 2) to the rear legs, skipping the top two holes and using the next four holes from the top of each leg. **NOTE: The legs are symmetrical, so the front and rear of the bench will be determined by where you place the stringer.** Attach with eight $\frac{1}{4}$ "-20 x $\frac{5}{8}$ " bolts, nuts, and lock washers (Ref. Nos. 18, 19, 20), four on each side.

NOTE: The stringer attaches to the flat area of the leg. For flared legs, this will be on the inside of each leg; for the adjustable legs, this will be on the outside of each leg.

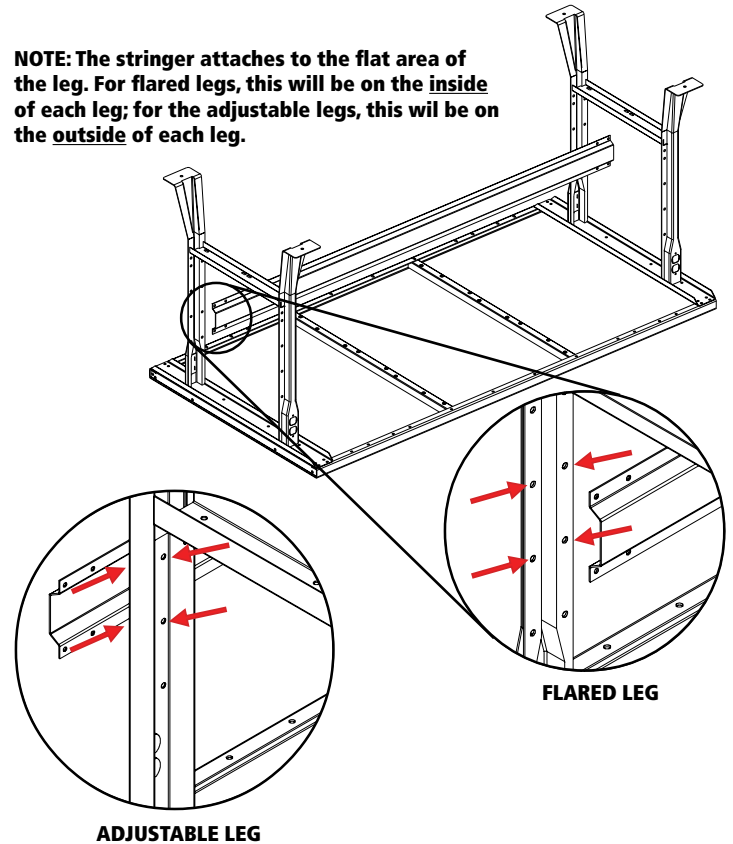

4. If you purchased only the basic workbench, your bench is now complete. The remaining instructions show assembly of optional accessories (such as the workbench drawer, the lower shelf, side and back rails, or risers).

NOTE: If attaching an optional drawer, you may want to leave the bench in the upside-down position.

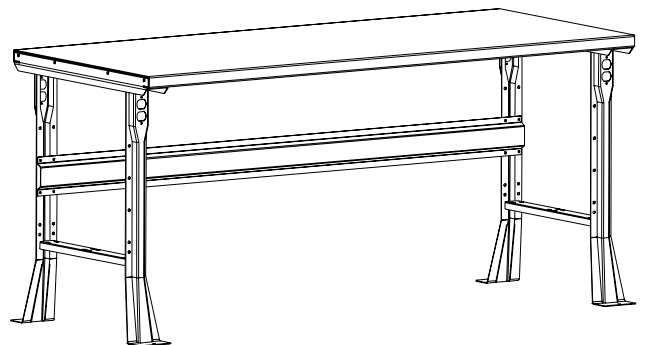

OPTIONAL ACCESSORIES

Optional Workbench Drawer

1. Remove the drawer (Ref. No. 6) from the drawer housing (Ref. No. 7).

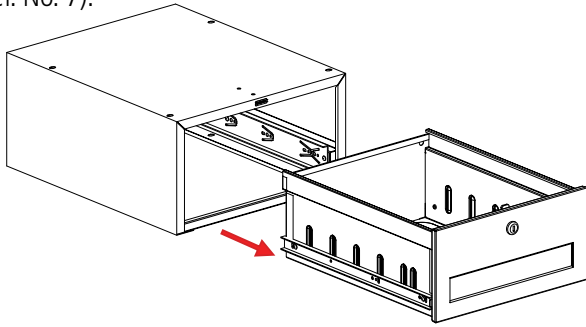

2. Attach the two mounting brackets (referred to in step 2 on the previous page) in the desired location on the workbench top. It is most common to place the drawer to either the far left or far right side of the bench, but can be placed anywhere that there are two holes in the bench top that are 15" apart. Secure with two $\frac{1}{4}$ "-20 x $\frac{5}{8}$ " bolts per mounting bracket.

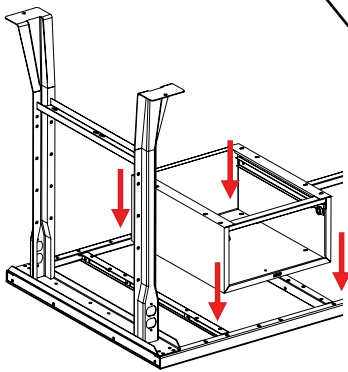
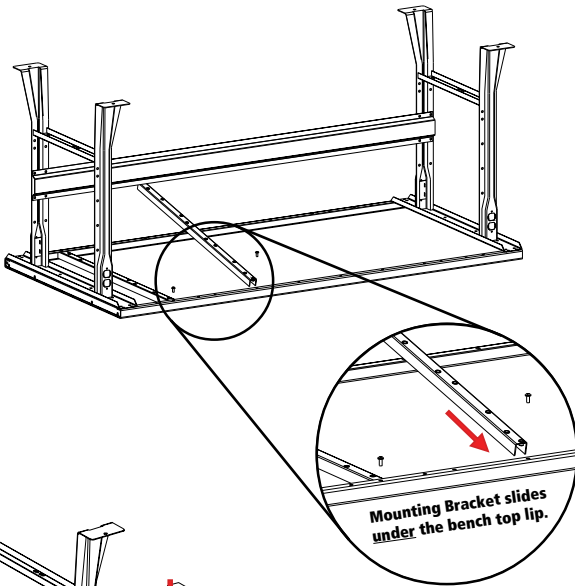

3. Attach the drawer housing to the mounting brackets. Secure with four $\frac{1}{4}$ "-20 x $\frac{5}{8}$ " bolts.

4. With the workbench upright, slide the drawer back into the drawer housing.

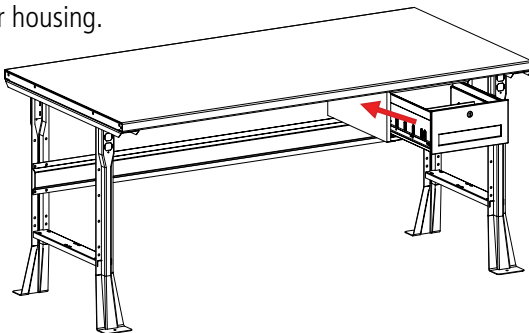

Optional Lower Shelf

1. Place the shelf (Ref. No. 12) on the brace of each leg. Attach with three $\frac{1}{4}$ "-20 x $\frac{5}{8}$ " bolts and nuts on each end of the shelf shown.

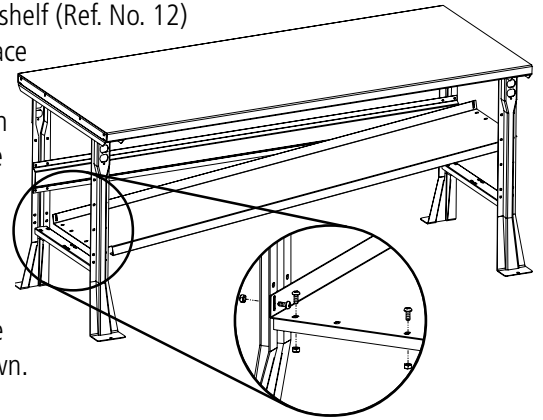

Optional Riser or Electronic Riser

For assembly and installation of a riser or electronic riser, please refer to the instructions which came with the riser kit.

Optional Side and Back Rails

1. If you are installing the optional side and back rails, and are also installing an optional riser, the riser must be in position first. **NOTE: The riser and rails share some of the same bolts and nuts. To avoid having to re-do parts of the installation, please refer to the riser instructions as you install the side and back rails.**
2. Place a side rail (Ref. No. 13) on one side of the workbench top, making sure that the rounded edge is toward the front of the bench. Attach with four $\frac{1}{4}$ "-20 x $\frac{5}{8}$ " bolts and nuts along the bottom edge. Repeat this step for the other side of the workbench.

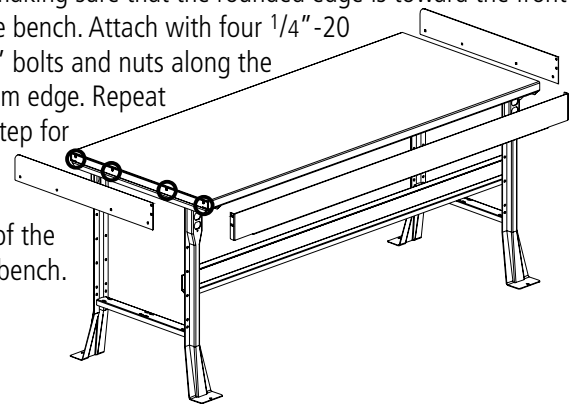

3. Attach the back rail (Ref. No. 14) by placing the flange of the rail under the bench top. Attach with eight $\frac{1}{4}$ "-20 x $\frac{5}{8}$ " bolts and nuts along the bottom.

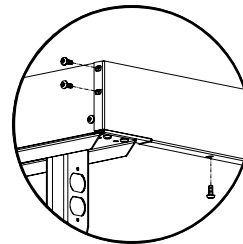

NOTE: Where there is a mounting bracket under the bench, you will first need to remove the bolt from the mounting bracket. The bolt will go through both the back rail and the mounting bracket. No nut will be needed in these locations.

4. Attach the back rail to the side rails, using two $\frac{1}{4}$ "-20 x $\frac{5}{8}$ " bolts and nuts on each end.

REPLACEMENT PARTS

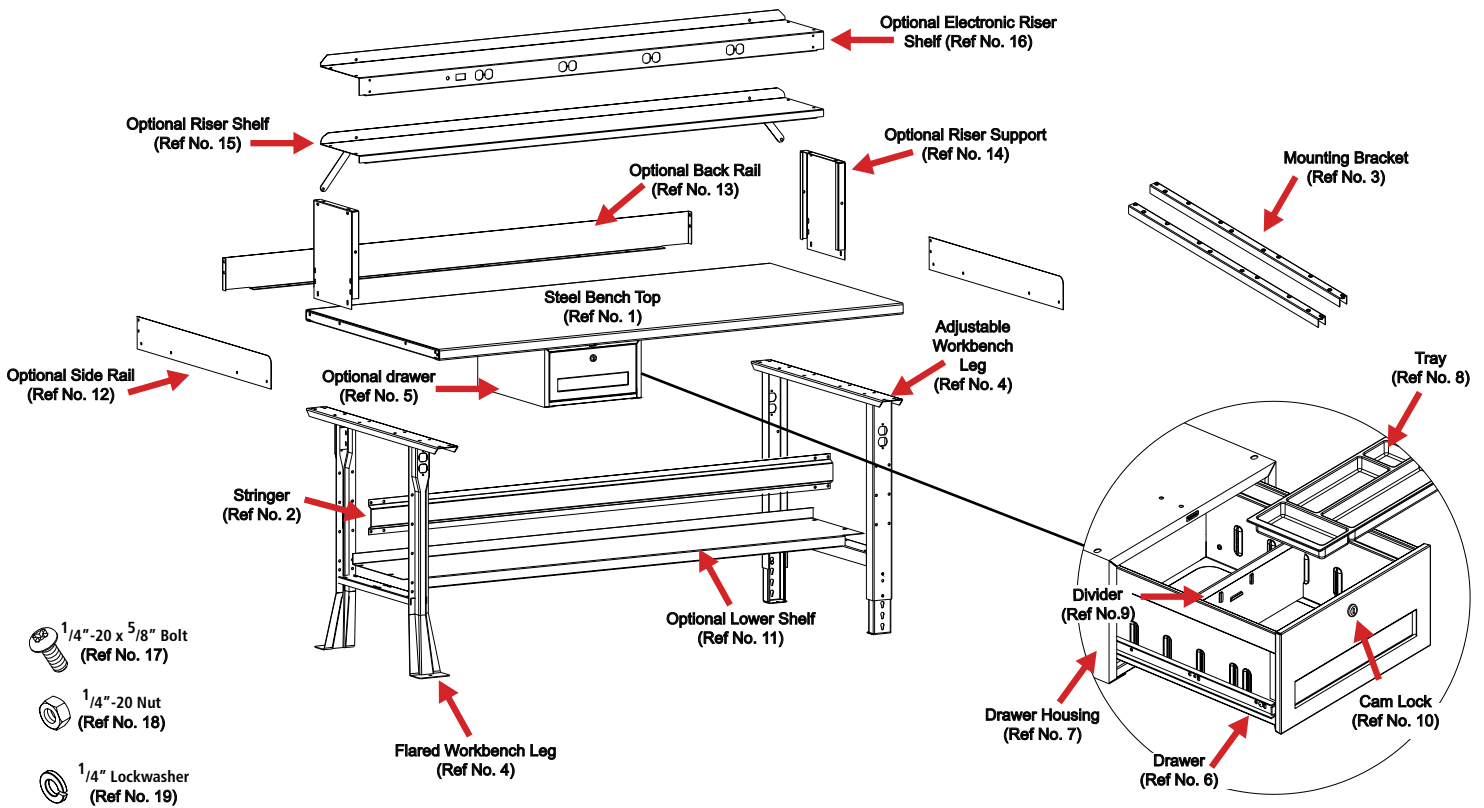

REF. NO.	DESCRIPTION	QTY.	PART NUMBERS						
			60" w x 30" d	60" w x 36" d	72" w x 30" d	72" w x 36" d	96" w x 30" d	96" w x 36" d	
1	Steel Bench Top (with Stringer)	1	T-3060	T-3660	T-3072	T-3672	T-3096	T-3696	
2	Stringer (included with bench top)	1	WBS-60	WBS-60	WBS-72	WBS-72	WBS-96	WBS-96	
3	Mounting Bracket (included with top)	1	WBMC-30	WBMC-36	WBMC-30	WBMC-36	WBMC-30	WBMC-36	
4	Flared Workbench Leg	OR	◆ 2	L-3230	L-3236	L-3230	L-3236	L-3230	L-3236
	Adjustable Workbench Leg	◆ 2	AL-3230	AL-3236	AL-3230	AL-3236	AL-3230	AL-3236	
5	Optional Drawer (complete unit)	1	WBD-1	WBD-1	WBD-1	WBD-1	WBD-1	WBD-1	
6	*Drawer	1	976CDW	976CDW	976CDW	976CDW	976CDW	976CDW	
7	*Drawer Housing	1	976CDH	976CDH	976CDH	976CDH	976CDH	976CDH	
8	*Tray	1	976T	976T	976T	976T	976T	976T	
9	*Divider	1	WBDD-12	WBDD-12	WBDD-12	WBDD-12	WBDD-12	WBDD-12	
10	*Cam Lock w/Keys	1	CL-1	CL-1	CL-1	CL-1	CL-1	CL-1	
11	Optional Lower Steel Shelf	1	S-60	S-60	S-72	S-72	S-96	S-96	
12	Optional Side Rail	2	189SS	404SS	189SS	404SS	189SS	404SS	
13	Optional Back Rail	1	189BS	189BS	404BS	404BS	BR-96	BR-96	
14	Optional Riser Support	2	WBRS-2	WBRS-2	WBRS-2	WBRS-2	WBRS-2	WBRS-2	
15	Optional Riser Shelf	1	WBRS-60	WBRS-60	WBRS-72	WBRS-72	WBRS-96	WBRS-96	
16	Optional Electronic Riser Shelf	1	EWRS-60	EWRS-60	EWRS-72	EWRS-72	EWRS-96	EWRS-96	
17	1/4"-20 x 5/8" Bolt	24	**	**	**	**	**	**	
18	1/4"-20 Nut	12	**	**	**	**	**	**	
19	1/4" Lockwasher	8	**	**	**	**	**	**	

*Included in Ref. No. 5, optional drawer (Part No. WBD 1).

** Available Locally

◆ 96" w workbenches arrive with 3 legs instead of 2 for stability.

NOTE: Additional hardware may be included for replacement purposes.

Tennsco makes every effort to ensure that all units ship complete with all parts and arrive undamaged. However, should your unit contain missing or damaged parts, please contact your purchase location.